



INSTRUCTION MANUAL FOR THE STRINGING MACHINE ML100 AND THE ML90.

CONTENTS:

A. TO PREPARE THE MACHINE FOR USE.

1. Assembly of the tension unit and the turntable.
2. Fixing the lever of the tension unit.
3. From which side do you want to use the machine?
4. Putting the turntable on the shaft.
5. Moving the table lock from one side to the other (ML100).

B. THE OPERATION OF THE MACHINE.

1. Adjusting the tension.
2. To pull tension on a string.
3. Mounting a tennis racquet.
4. Mounting a badminton racquet.
5. Mounting a squash racquet.
6. Using the clamp systems.

C. THE MAINTENANCE OF THE MACHINE.

1. Cleaning the string clamp of the tension unit.
2. Cleaning the clamps.
3. The clamp system.

D. OVERHAUL OF A STRINGWAY CLAMP.

A. TO PREPARE THE MACHINE FOR USE.

This video shows the assembly

<https://www.youtube.com/watch?v=mY6pLPNT1ow>

A1. Fixing the tension unit on the frame.

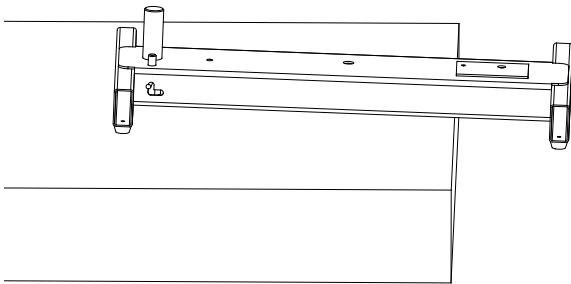

FIG. 1

- Place the frame of the machine over the edge of a table (Fig.1).
- Place the tension unit on the frame with the eye bolt through the hole in the frame and the housing around the positioning plate that is fixed on the frame.
- Slide the bushes of 30 and 7,5 mm long over the eyebolt into the frame.
- Place the washer and the nut over the eyebolt.
- Tighten the nut firmly with a spanner.

A2 Fixing the lever of the drop weight system [fig 3].

To save space when the machine is not in use, the lever of the drop weight system can be removed. Fig. 3 shows the sequence of the actions to remove the lever.

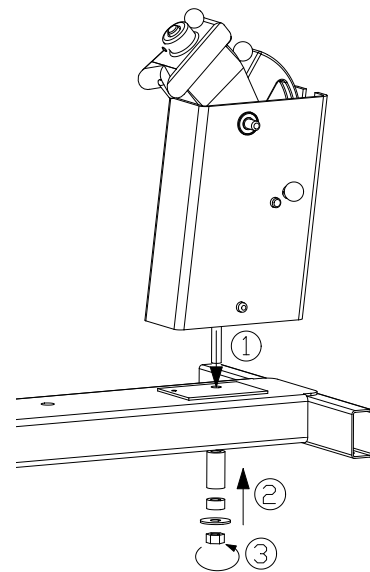

FIG. 2

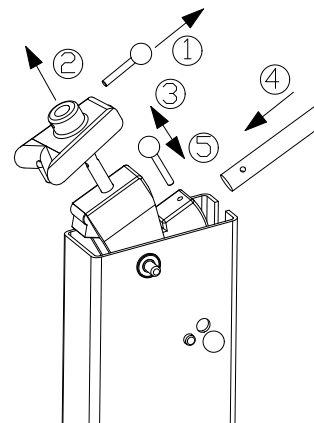

FIG.3

A3. From which side do you want to use the machine?

The drop weight system can be used from both sides. When there is no preference it is advised to insert the string with your “handy” hand and to lift the lever with the other one. So if you are right handed position the tensioner at the left side and the turntable at the right side.

The “unlock-button” of the tensioner can be moved from one side to the other . Unscrew the ball knob and unscrew the screw with a pair of pliers and screw it into the locking bar on the other side.

A4. Mounting the turntable over the shaft.

Unscrew the bolt in the shaft on machines with Concorde system.

Slide the turntable over the shaft and screw the bolt back in. Check if there is grease inside the delrin bush, if not add a thin layer of grease into the bearing.

The ML100 has a table lock so that the turntable can be locked in 12 positions. When the lever is in the upper position the table will lock as soon as the locking pin meets a hole in the turntable.

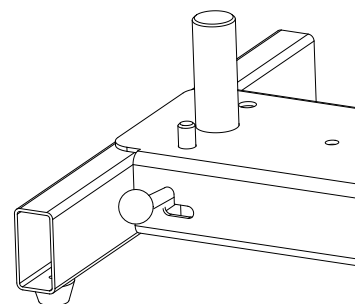

FIG.4

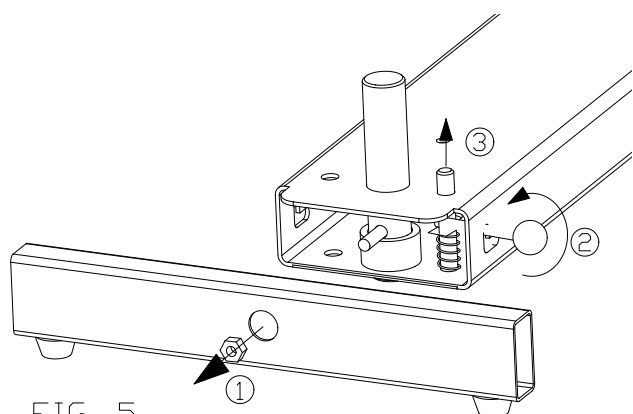

FIG. 5

A5. Moving the table lock to the other side.

The table lock on the ML100 can be moved from one side to the other when the machine will be used from the other side. Fig. 5 shows the actions of disassembly.

The assembly goes in the opposite direction.

B. THE OPERATION OF THE MACHINE.

B1 Adjusting the tension.

* The tension can be adjusted between 4.5 and 37 kg or 10 to 81 lbs in 3 steps:

- Small weight: 4.5 to 10 kg. or 10 to 22 lbs.
- Large + small weight: 10 - 31 kg or 22 to 68 lbs.
- Large + small weight + extra small weight: 31 - 37 kg or 68 to 81 lbs.

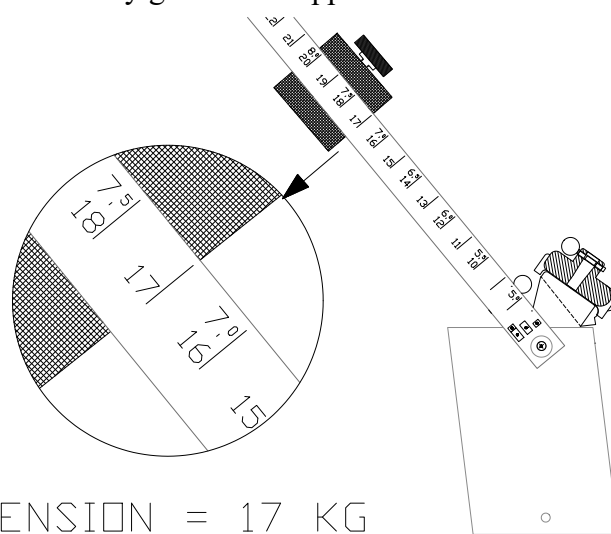

TENSION = 17 KG

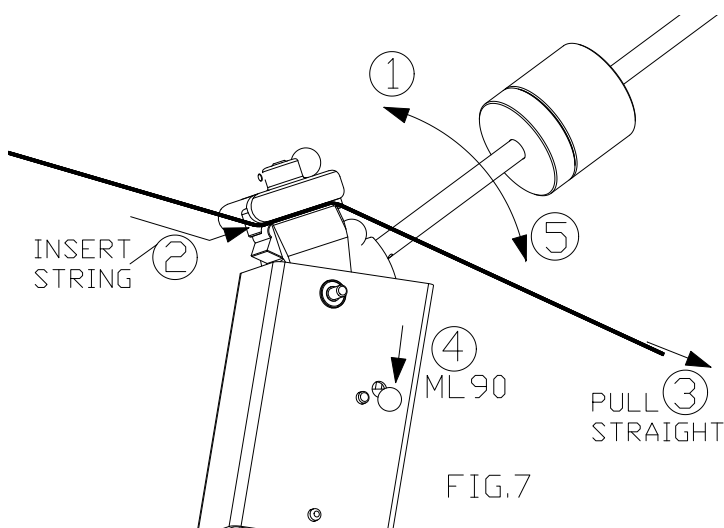

FIG.7

B2. To pull tension on a string.

* The locking system:

The ML100 and the ML90 have an automatic locking system on the tension head;

- The tension head is locked in the starting position when no string is clamped in the tension head.
- On the ML90 the lock can be released by hand.
- On the ML100 the lock is released automatically when a string is clamped.

* To insert the string in the string clamp (Fig.7).

- Lift the lever to open the string clamp.
- Pull the string straight along the bottom side of the upper jaw and guide it into the slot between the upper and the lower clamping surface.
- The string can also be guided round the back of the system.
- Release the lock (ML90) by pushing down the release knob.
- Lower the lever to clamp the string.

Always take good care that the string lies against the cams of the upper jaw when the string is clamped (fig. 10A)!

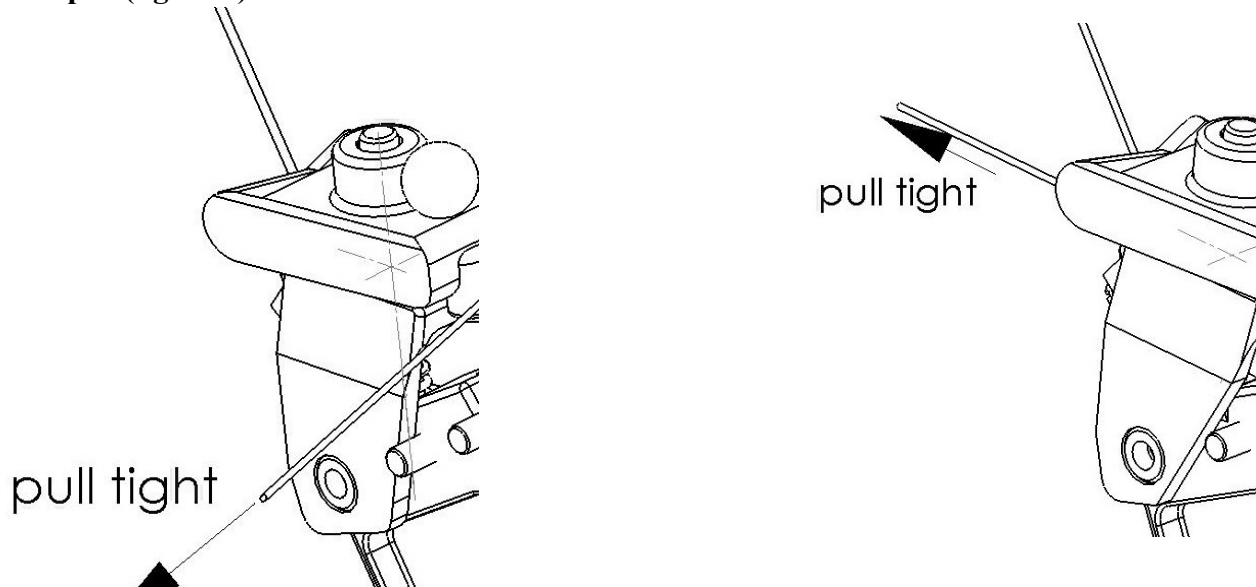

“TO DOUBLE CLAMP THE STRING” (fig. 10B)

To lower the pressure the string can also be clamped “double” using the front and the backside of the string clamp:

- Wrap the string around the tension head.
- Lift the lever to open the string clamp.
- Pull the string straight towards the front.
- Move the string into the clamp at the front side.
- Lower the tension lever.

IMPORTANT:

To get the adjusted tension in the string and not over tension the string:

- Only support the lever going down until it stops, **do not** pull the arm downwards.
- The tension in the string is right for every angle of the lever.

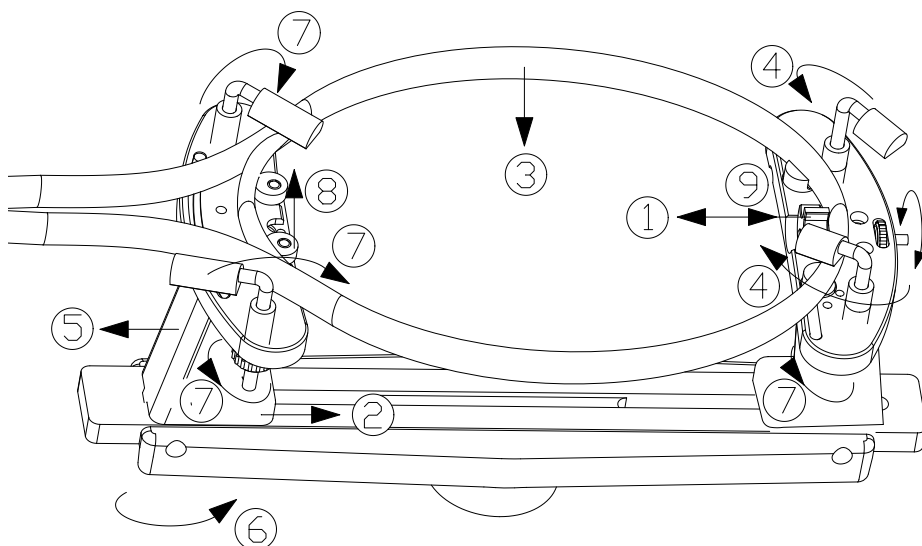

FIG. 11

B3. Mounting a tennis racquet

It is not necessary to mount the racquet in the middle of the turntable, Leave the head support at one end of the table and move the throat support up and down to adjust it to the size of the racquet. Mounting a tennis racquet goes as follows, the numbers in figure 11 show the sequence of the actions.

- 1) Move the central head support inwards.
- 2) Move the throat support inwards so that the racquet fits over the supports.
- 3) Put the racquet on the support plates, with the central main string positions at each side of the central support. Place the racquet against the inside supports.
- 4) Put the clamping hooks at the head side on the racquet and turn the knob upwards so that the racquet can not move off the plate.
- 5) Move the throat side post outwards until the flat side of the supports lie against the racquet
- 6) Fix the throat side post in that position with the clamping knob at the bottom.
- 7) Put the clamping hooks at the throat side on the racquet and tighten all clamping hooks.
- 8) Adjust the throat side supports upwards until they lie 2 mm below the tubes in the grommet.
- 9) Adjust the central against the racquet until it just hits the racquet.

Check if the knobs that fix the posts are tightened!

“Babolat” retainer.

The Babolat retainer is used instead of the normal supports for racquets with a low-profile-bridge.. But it can be used for most racquets if the stringer prefers that.

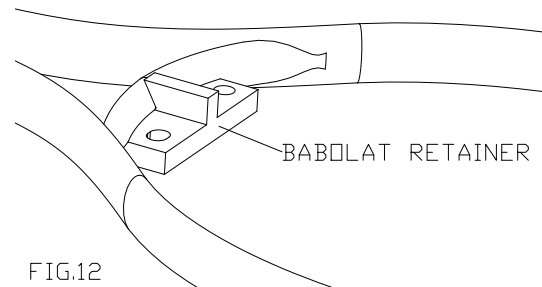

FIG.12

B4. Mounting a badminton racquet (fig. 13).

A badminton racquet is clamped differently from a tennis racquet:

- The racquet is mounted “the other way around” compared with a tennis racquet.
- Higher red badminton supports are used at the head and the throat side instead of the white tennis supports.
- The clamping hooks at the head side are not used to clamp a badminton racquet.
- The clamping piece with the screw is used to clamp the racquet.

The screw must be fixed in the swivel plate and the clamping piece is clamped by tightening the knurled knob.

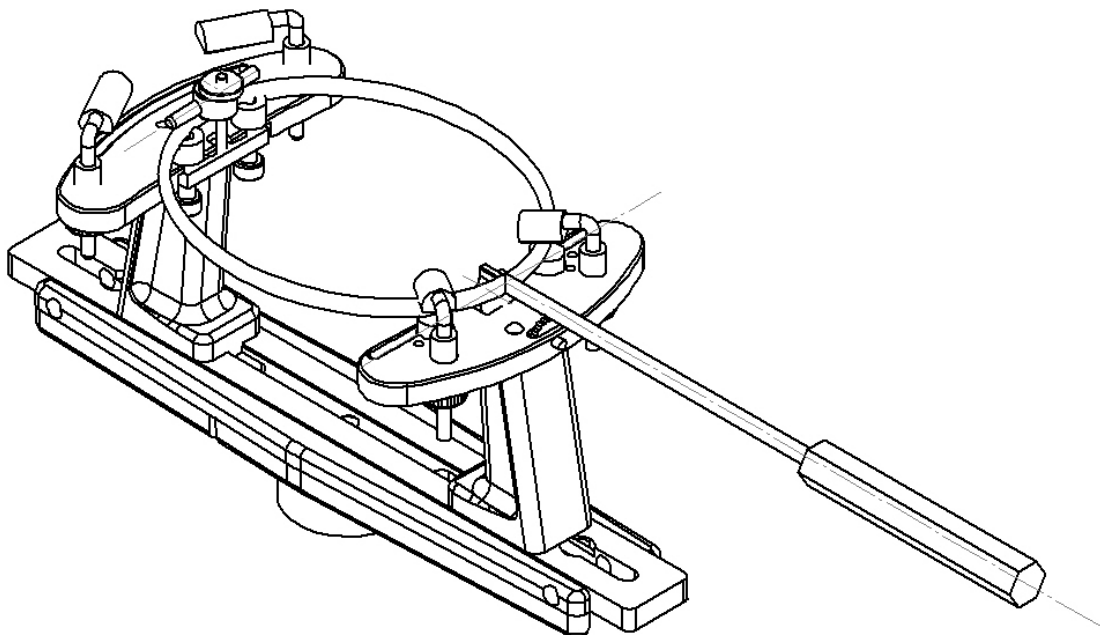

B5. Mounting a squash racquet.

Both support systems can be used for squash racquets, depending on the shape and the height of the profile.

B6. Using the clamp systems.

All M machines can be supplied with 3 clamp systems, flying clamps, double action fixed clamps and single action clamps.

B6a Using flying clamps TH.

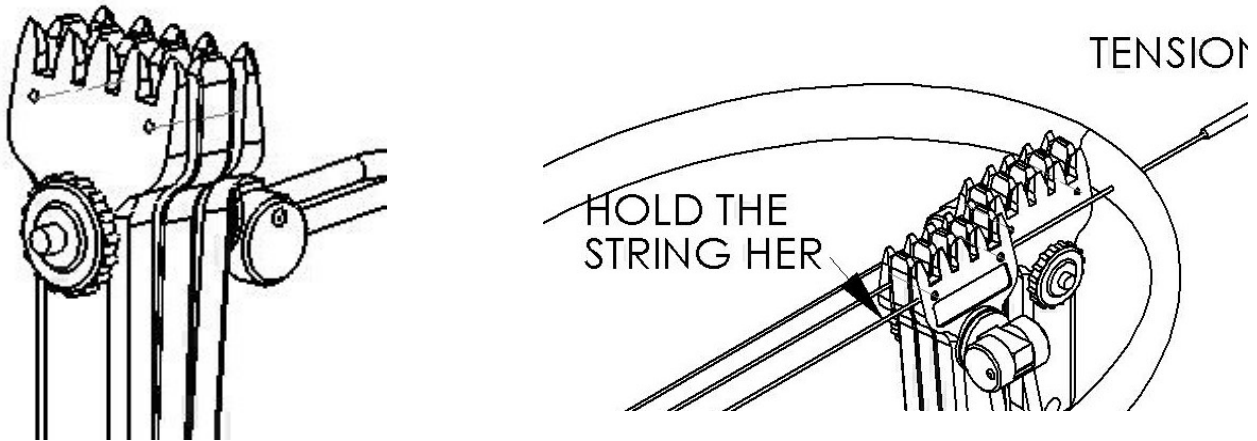
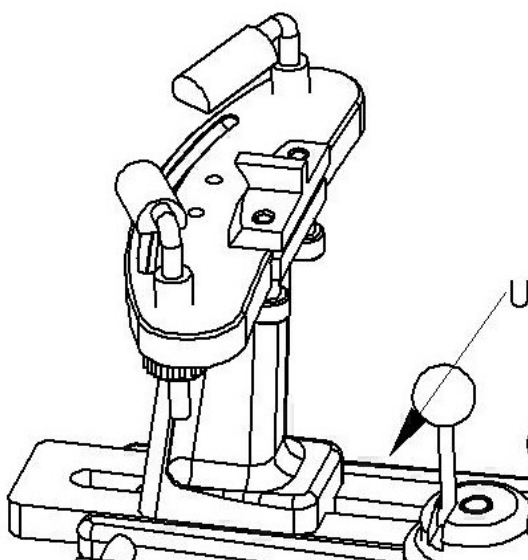

Figure 14 shows the flying clamp.

A flying clamp holds the tension by clamping the last string to the string before last. The knob is used to adjust the clamp to the diameter of the string that is used.

Figure 15 shows the way to start with the center main strings with 2 flying clamps:

- 1) Clamp the center main strings in the first clamp near that side where the mains start.
 - 2) Pull tension on the first and second main string towards the head.
 - 3) Clamp the second string in position the clamp close to the other clamp.
 - 4) Check the adjustment of the clamps before every string job as shown as described in chapter B6d.
 - 5) Continue by tensioning the mains and take care that the mains have to go in symmetrically.
- Keep about the same number of strings at each side of the center.



B6b Using Double action fixed clamps T98.

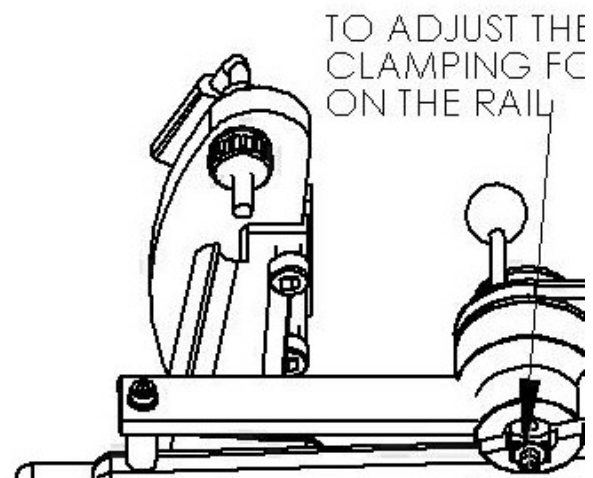

With double action system T98 the string is clamped first and after that the system is clamped on the guiding rails and in rotational direction by switching the handle (fig.16)

The clamping force of the guiding system can be adjusted with the nut (fig.17).

VERY IMPORTANT:

- The clamping force on the rail should only be adjusted with the handle in the VERTICAL end position.

- During use the handle should always reach the vertical end position to be stable.

The clamp can be adjusted to the diameter of the string which is used with adjustment wheel at the back side of the clamp.

B6c Using the single action fixed clamps T92.

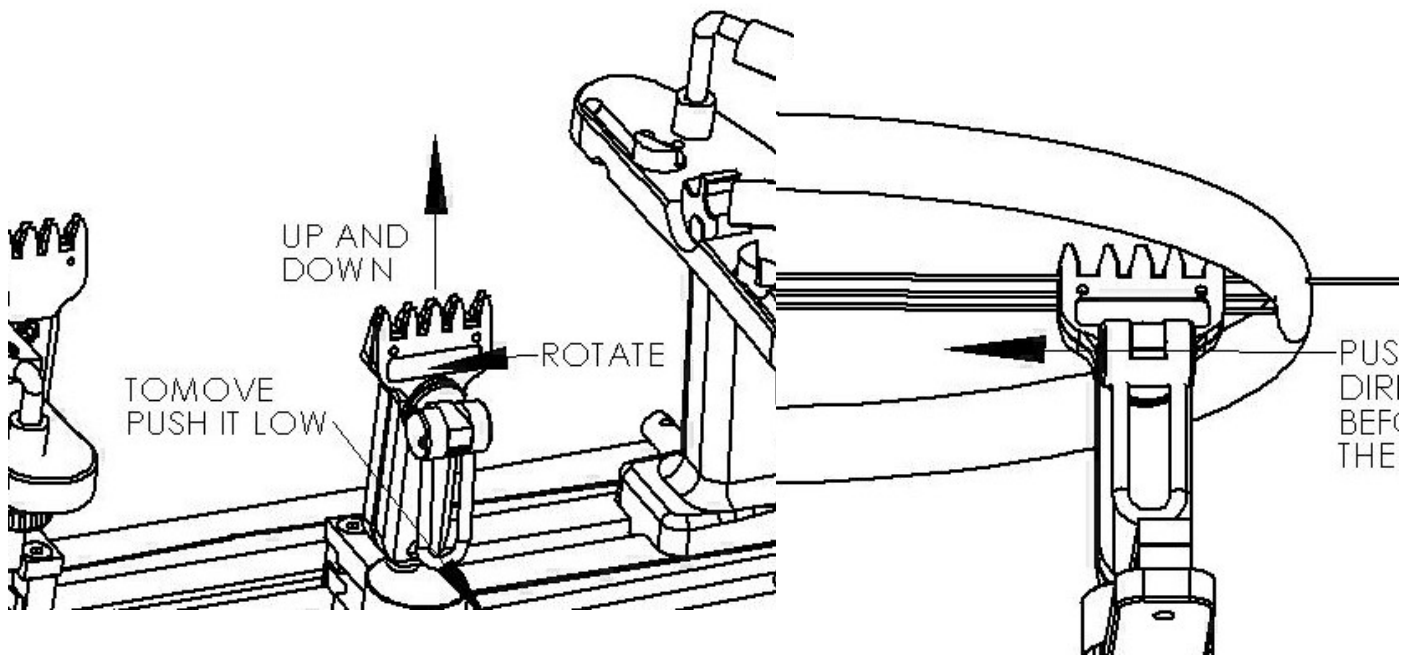

The tensioned string locks the guiding system of T92 locks automatically.

The system can move in X and Y direction and the clamp can rotate and move up and down.

Fig.18 shows the movements of the T92 system.

The movement in the X and Y direction goes easy when the system is pushed in a low position close to the guiding system.

When one pushes too high the system will lock.

To obtain minimum movement of the clamp when the clamp takes over the tension from the tensioner, push the clamp in the pulling direction of the string (Fig.19)

B6d Checking the clamp adjustment.

It is very important to avoid sliding of the strings through the clamps, because that will result in loss of stringbed stiffness.

Therefore it is important to check the adjustment of the clamps for EVERY string job as shown in figure 15 and 19:

- Hold the string behind the clamp.
- Release the tensioner.
- Check if the string slides through the clamp.

If the string slips through the clamp there can be 2 reasons:

- The clamp is greasy and has to be cleaned. (See C2).
- The clamp has to be adjusted at the diameter of the string and at the tension that is used.



B7 The Concorde system.

The Concorde system is used to pull tension without friction on the main strings in the bridge of a

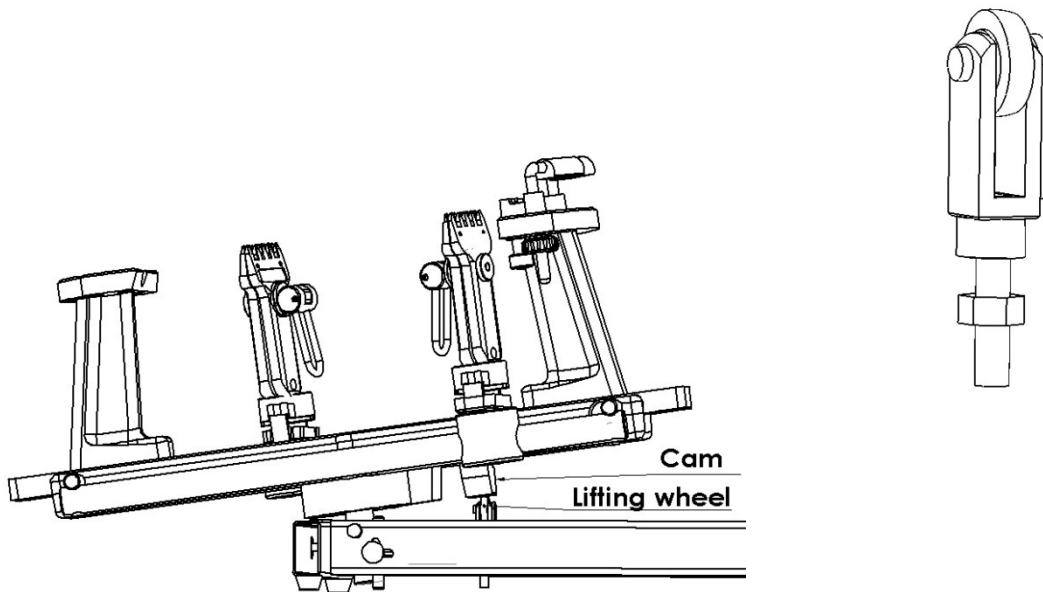

tennis racquet. The turntable tilts “automatically” when the handle of the racquet is pushed towards the tension unit. The cam under the turntable is lifted by the lifting wheel so that the turntable tilts and the handle can rotate over the tensioner.

The amount of tilting can be adjusted by adjusting the lifting wheel higher or lower. Unscrew the nut under the frame, so that the bracket with the wheel can be lifted from the frame after rotating it a quarter revolution. The turntable will tilt more or less by adjusting the second nut higher or lower.

C. THE MAINTENANCE OF THE MACHINE.

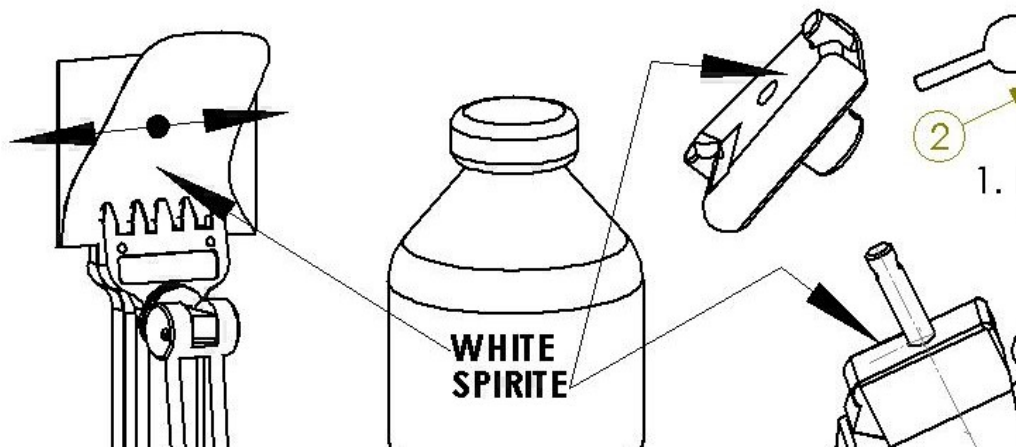

C1. Cleaning the string clamp of the tension unit (fig. 20).

- * Lift the lever so that the string clamp opens and pull the pin out of the upper jaw (2).
- * Pull the upper jaw off the pull rod and clean the surfaces of the string clamp with white spirit.

C2. Cleaning the clamps [fig.20].

When the string slides through the clamp this can have 2 causes:

1. The adjustment of the clamp is wrong.
2. The silicone coating of the strings has made the clamp greasy, the clamp has to be cleaned:
 - * Fold a cloth around a thin plate and wet it with a degreasing fluid (white spirit).
 - * Move the plate and cloth between the jaws of the clamp, close the clamp and move the cloth and plate up and down between the jaws.

C3. The guide bars of the 'T92' clamp system.

The clamps can be moved very easy:

- * When the longitudinal guide bars are kept clean. (Don't use any grease!)
- * When a little vaseline is put on the cross guide bars.
- * Put some grease every now and then on the pin that holds the clamp.

C5. The guide bars and clamps of the clamp system 'T98'.

When the guide bars are greasy the clamps can slide over the guidebars. Clean the guidebars regularly with white spirite.

D. OVERHAUL OF A STRINGWAY CLAMP.

After extensive use the clamps of the Stringway machines can be overhauled quite easily. Figure 1 shows the parts of the clamp.

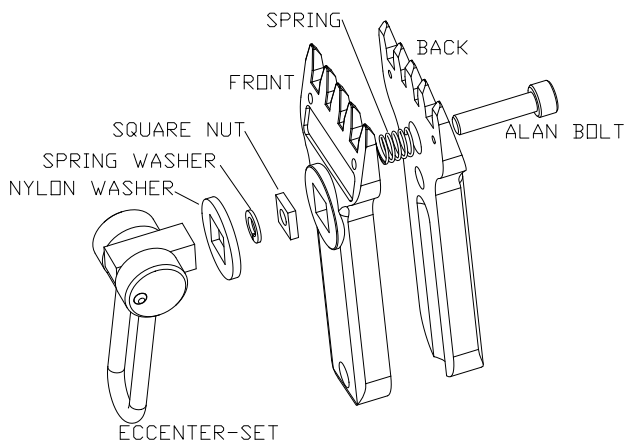

FIGURE 1

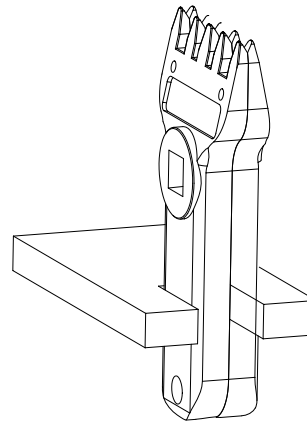

FIGURE 2

DISASSEMBLY

For the disassembly and assembly it is easy to use a vise or a special piece of wood with a slot in it to hold the clamp as shown in figure 2.

To disassemble the clamp unscrew the Alan bolt and take of the closing mechanism.

GRINDING THE CLAMP PARTS.

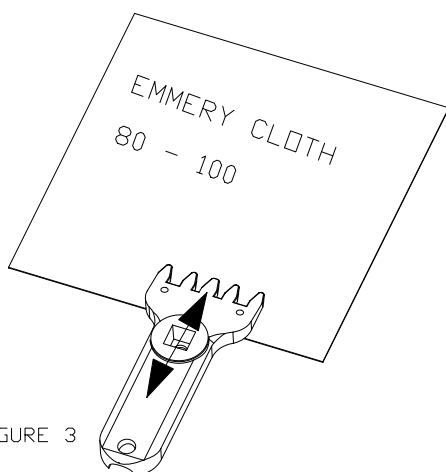

FIGURE 3

To clamp the string with a minimum clamping force the clamping surface must be equally rough. Grind the clamping surface by moving the clamp up and down over a piece of grinding cloth. Support the grinding cloth on a flat surface like a table.

THE ASSEMBLY OF THE CLAMP.

- Put the spring in the hole between the front and the back of the clamp.

- Clamp both castings on top of each other in the clamping device.
- Put the Alan bolt in from the back.
- Put the square nut on the Alan bolt and screw the bolt into the nut until the nut is level with the surface of the clamp.
- Slide the spring washer over the Alan bolt.

- Turn the pull rod of the eccentric set on the Alan bolt until it compresses the spring washer completely.

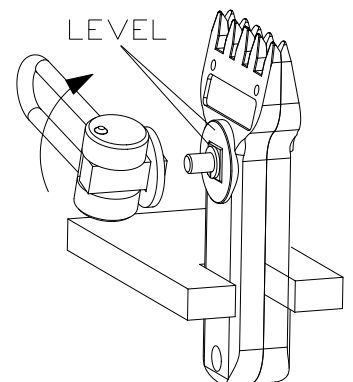

FIGURE 4

- Turn the pull rod $\frac{1}{4}$ revolution backwards.
- If the eccentric is in the right position, with the handle downwards, turn the Alan bolt into the pull rod until the nylon washer hits the surface of the clamp.

If the closing mechanism is in the wrong position:

- Unscrew the Alan bolt holding the eccentric, so that the square nut comes out of the hole in the clamp.
- Turn the pull rod / eccentric in the right position.
- Turn the Alan Bolt into the pull rod until the nylon washer hits the surface of the clamp.

GREASING THE CLAMP.

For easy up and down sliding of the clamp it is advised to insert a thick layer of grease into the hollow that clamps the clamp on the pin of the sliding system.

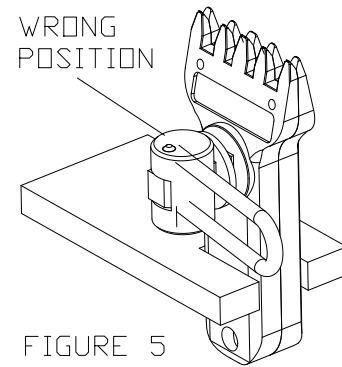

We wish you much pleasure with your ML90 / ML100 stringing machine
